

A-A

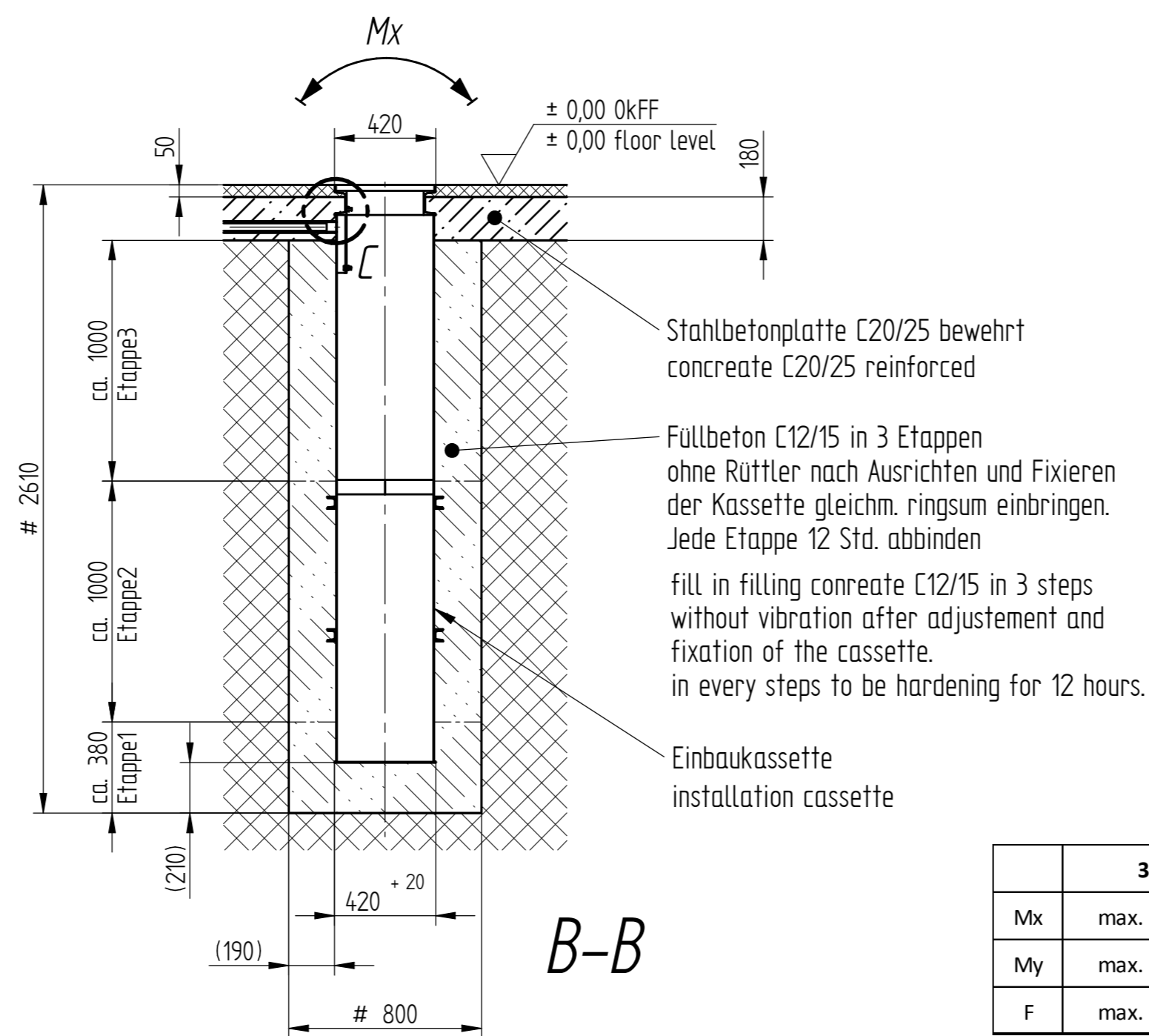

B-B

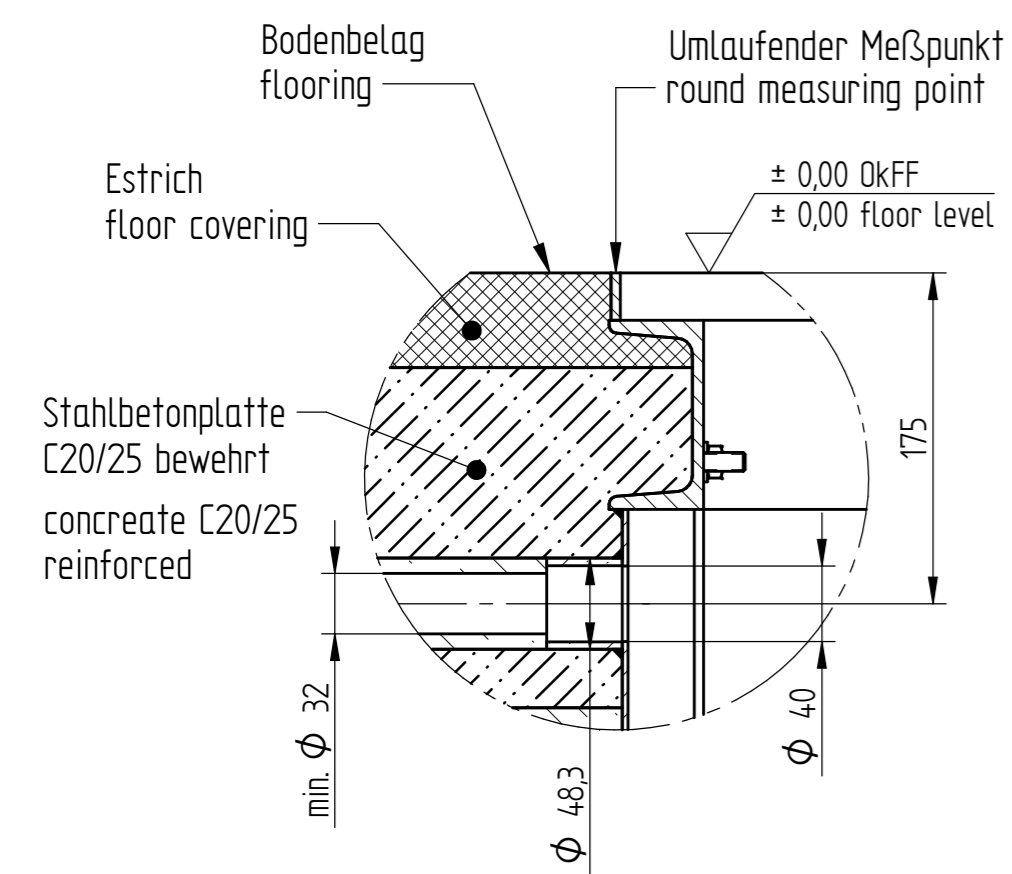

INZELHEIT C

Alle Maße sind Mindestmaße in mm
all dimension are minimum in mm

Stempelabstand 2685 (Ölhydraulik)
piston distance 2685 (oil hydraulics)

= Mindestmaß, sonst nach Bodenbeschaffenheit
= minimum, otherwise acc. to foundation requirements

	3,5 t	5,0 t
Mx	max. 30 kNm	max. 45 kNm
My	max. 35 kNm	max. 45 kNm
F	max. 45 kN	max. 65 kN

<p>Herrmann AG Bahnhofstr. 32 93483 Posing</p>	Zeichnungsnummer	FP2685 H2408
	Stand	12.12.19
Fundamentplan SA2685		Zst. 0
Foundation plan SA2685		