

Herrmann AG
Bahnhofstrasse 32
D-93483 Pöding

Sales

Phone: +49 (0)9461/91388 50
Fax: +49 (0)9461/91388 55
E-Mail: sales@herrmann.de

Service

Phone: +49 (0)9461/91388 30
Fax: +49 (0)9461/91388 33
E-Mail: service@herrmann.de

www.herrmann.de

100% tension relieved car chassis. Air buffered aerone turning plates for wheel alignment at the highest precision level.

equipment trolley with control unit air supply

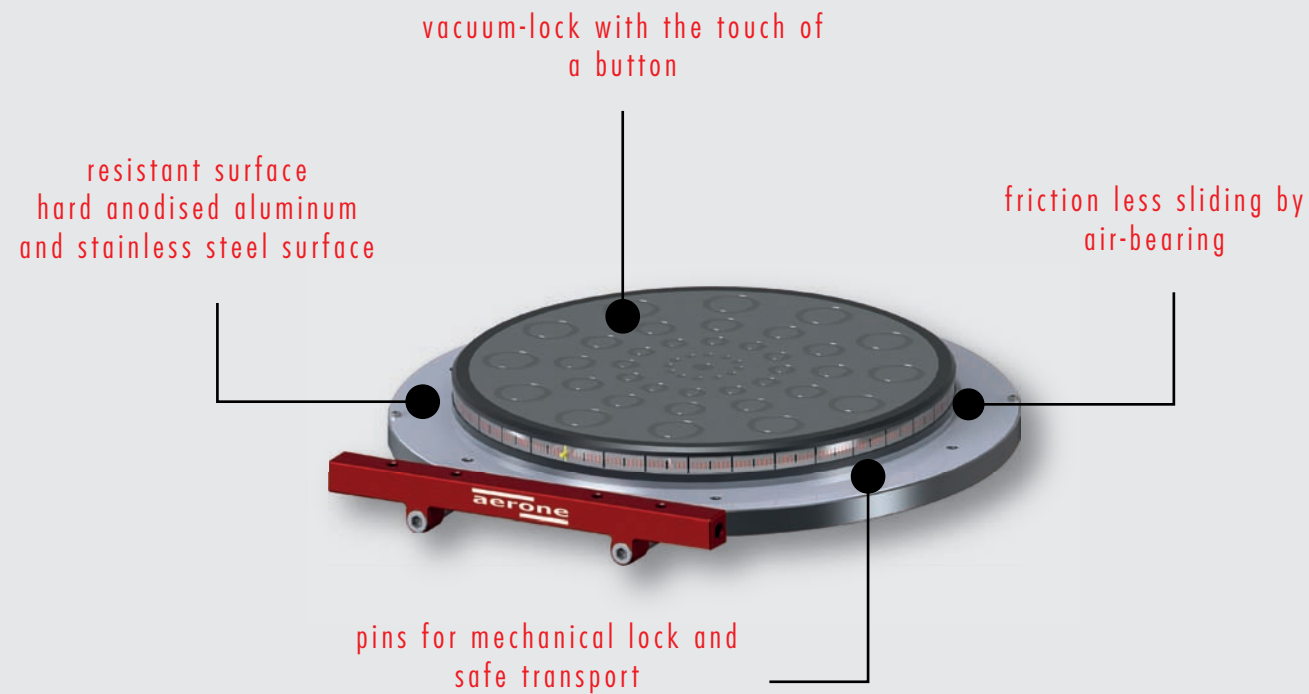

www.herrmann.de

technical data

system height	50 mm
sizes	440 x 500 mm
moving range x,y	70 mm
mass	17 kg
load capacity	20 kN
friction with load	0 N
air supply min.	6-8 bar
working pressure	2-4 bar
air consumption	20 - 80 l(n)/min

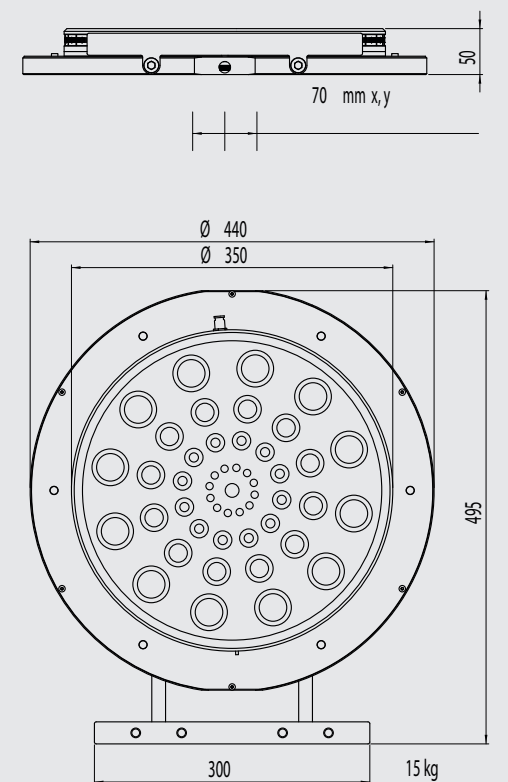

friction-free precision thanks to intelligent air bearing

Modern vehicles require accurate adjusted chassis. Increasing quality and more powerful engines of vehicles require higher accuracy to chassis adjustments and thus on the wheel alignment technique.

The frictionless air buffer of the unique aerone-system provides outstanding vehicle positioning for high-precision wheel alignment.

With the central control unit, the plates can be controlled individually or axle wise. For driving on/over, the units can be fixed by vacuum.

The aerone can be used as two- or four-plate-system.