

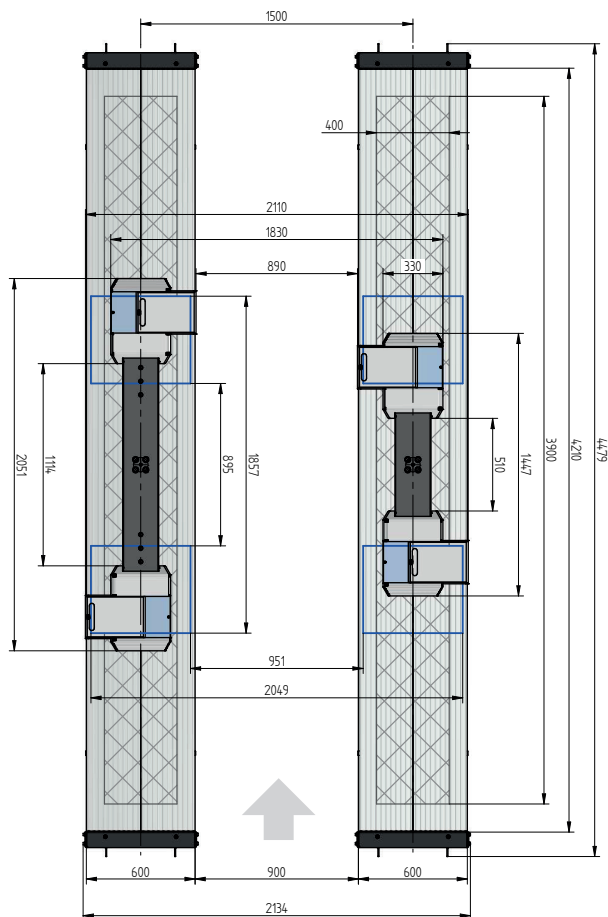

# Alu Track 2.35 Duplo Uni plus

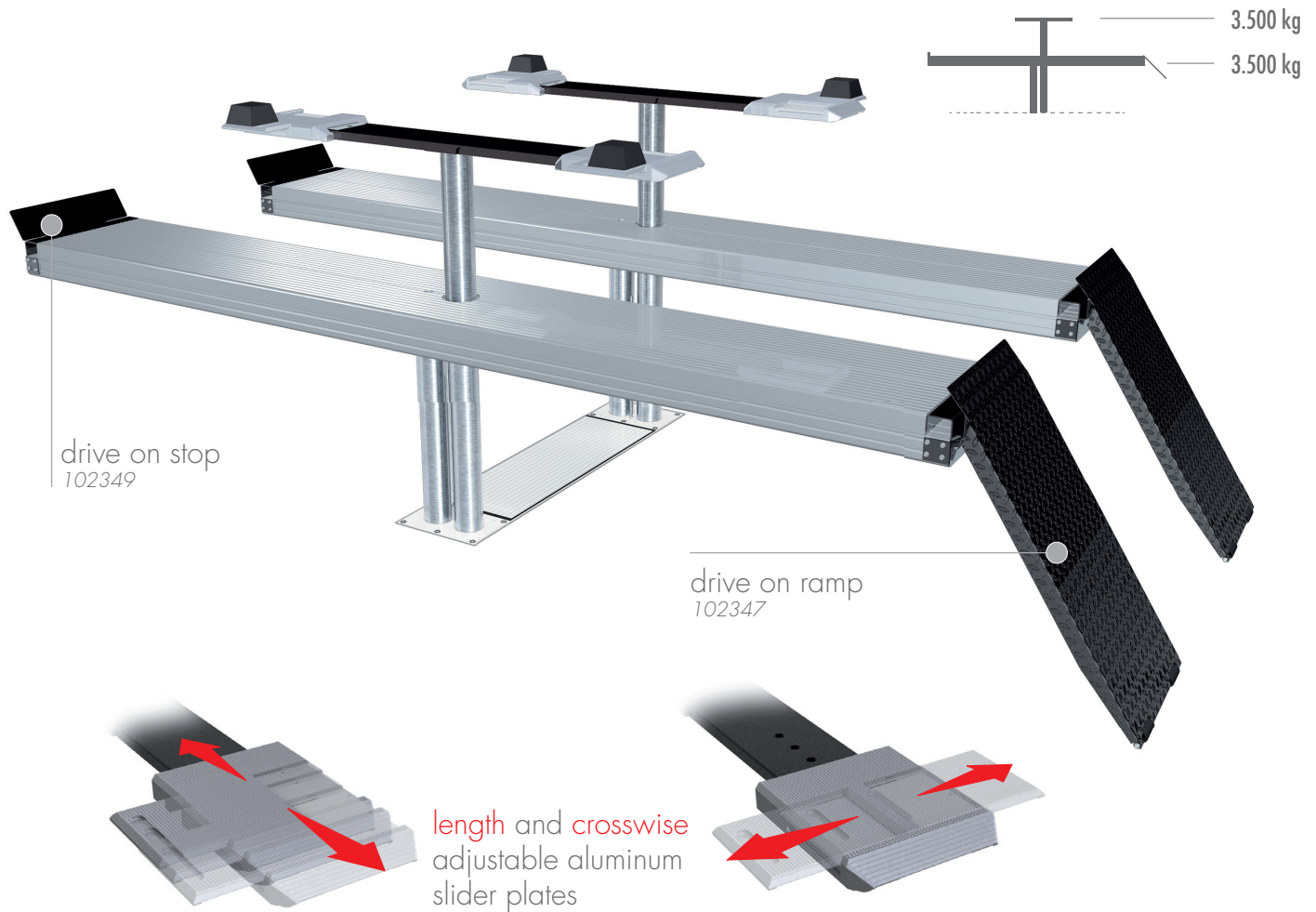

## TECHNICAL DATA

capacity	3500 kg
wheel free lift	3500 kg
effective raise height platform	1997 mm
lifting height wheel free unit	1982 mm
platform length	4400 mm
platform height	180 mm
drive over height wheel free unit	60 mm
piston diameter	123 mm
piston distance	1500 mm
installation depth	2443 mm
motor output	3,0 kW
power connector	400 V/16 A
cable length to control	11 m
lifting time	≈ 35 sec.
lowering time	≈ 35 sec.

Platform support Alu Track 2.35 Duplo	105336
Support Uni 2.35 plus	102640
Installation cassette STEEL 1500 mm	2190XX
Installation cassette STEEL 1500 mm galvanized	2191XX
Lifting unit oil 3,5 l Duplo 1500 mm - K pre-assembled in installation cassette	104962
Lifting unit oil 3,5 l Duplo 1500 mm - H packed in wooden box	104963

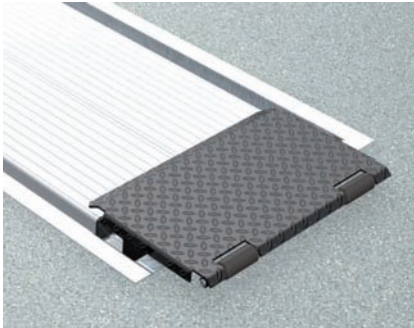

Drive on ramp  
for installation flush with floor level  
102346

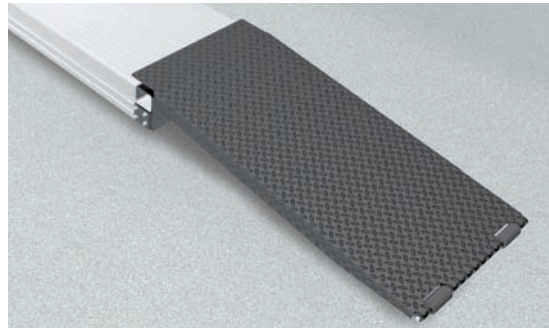

Drive on ramp  
for floor incumbent installation  
1250 mm, hanging, bevel 7°  
102347

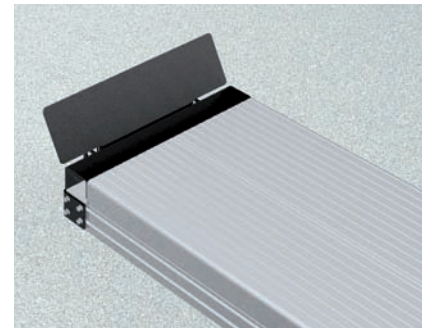

Drive on stop  
102349

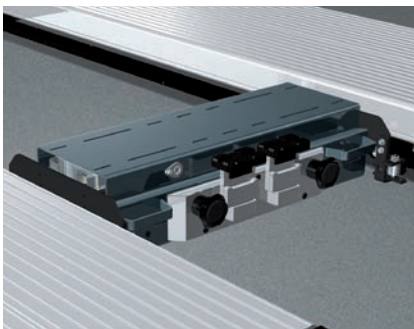

Axle lifter  
pneumatic, without slide rails  
2600 kg  
105063

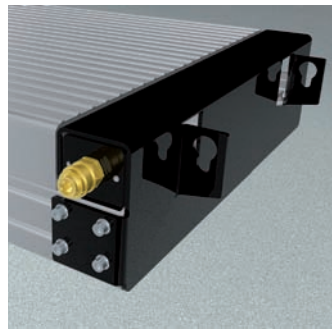

Compressed  
air supply  
for floor incumbent installation  
or rectangular foundation  
102407

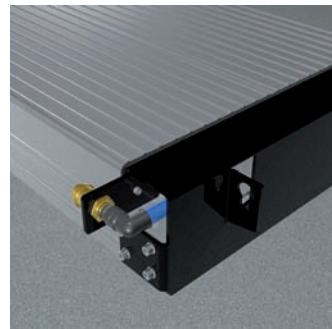

Compressed  
air supply  
for installation flush with  
floor level in H-frame  
105617



Wheel align-  
ment supports  
1350 mm  
102377  
600 mm  
102381



Slide rail set  
4400 mm  
102374

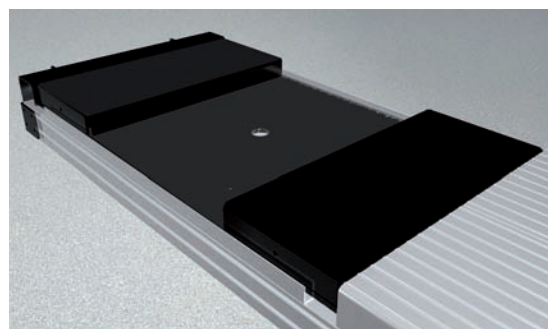

Platform support with platform notches for turn tables and  
for sliding plates incl. levelling plates

Alu Track 2.35 Duplo  
1200 mm/1200 mm  
105244

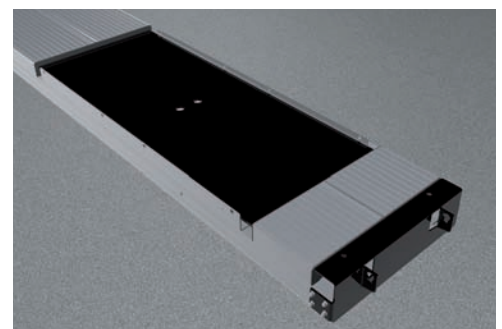

# Accessories

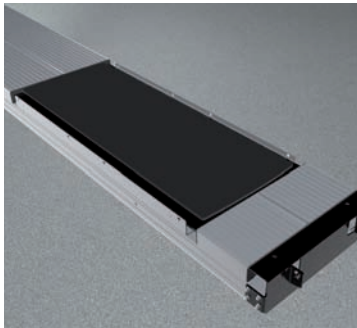

Sliding plate  
Precision

1200 mm  
102423

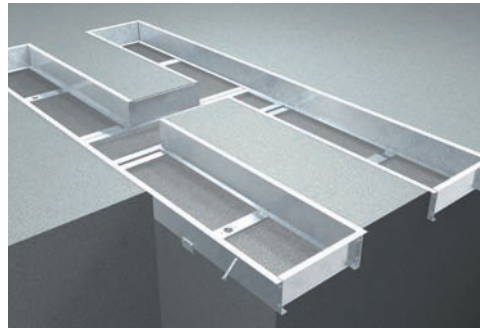

Surround frame 2-piston  
hot-dip galvanized,  
for installation flush with floor level

4400 mm  
102356

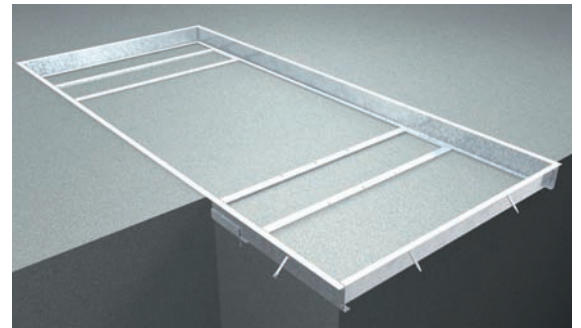

Surround frame rectangle  
hot-dip galvanized,  
for installation flush with floor level

2-pt. 4400 mm  
105335

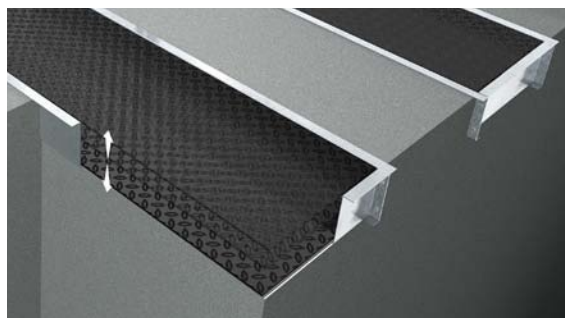

Automatic floor levelling system  
hot-dip galvanized and powder-coated

2-pt. DUPLO 4400 mm  
102363



Wheel free system Uni plus  
flush with platform

105179



Illumination set LED  
Alu Track

102394



Automatic  
lubrication

basic unit 2-piston  
105060



Park position sensor for  
pneumatic axle lifter

102456



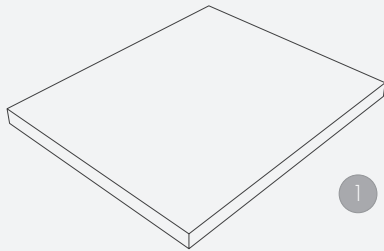

1 | Rubber pad  
290 x 335 x 20 mm  
102275 (1set / 4 pcs.)

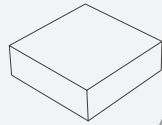

2 | Rubber pad  
120 x 120 x 40 mm  
102274 (1set / 4 pcs.)

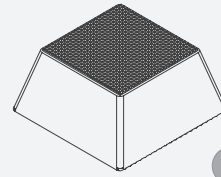

3 | Rubber pad pyramid  
70 mm  
102273 (1set / 4 pcs.)

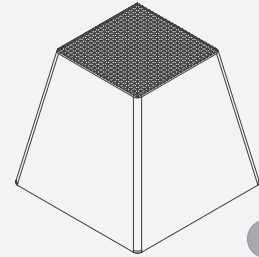

4 | Rubber pad pyramid  
140 mm  
102291 (1set / 4 pcs.)



**Herrmann AG**  
Bahnhofstrasse 32  
D-93483 Pöding

**Sales**

Phone: +49 (0)9461/91388 50  
Fax: +49 (0)9461/91388 33  
E-Mail: [sales@herrmann.de](mailto:sales@herrmann.de)

**Service**

Phone: +49 (0)9461/91388 31  
Fax: +49 (0)9461/91388 33  
E-Mail: [service@herrmann.de](mailto:service@herrmann.de)

[www.herrmann.de](http://www.herrmann.de)